

KS

42 BT S T

	KS 42 BT S T	Modello	Model	Modèle	Modell	Modelo	
°C	-18 ÷ -22°C	Campo applicazione	Application field	Champe d'application	Anwendungsbereich	Campo d'applicación	
	400V/3/50Hz	Alimentazione	Power supply	Alimentation	Netzanschluß	Alimentación	
A	12	Corrente max. assorbita	Max. absorbed current	Courant absorbé max.	Max. absorbierter Strom	Corriente máx. absorbida	
kW	5,7	Potenza max. assorbita	Max. absorbed power	Puissance max. absorbée	Max. aufgenommene Leistung	Máx. potencia absorbida	
	R404A/R507/ R452A	Tipo refrigerante	Refrigerant type	Tipe du gaz	Kältemittel	Tipo refrigerante	
W	3729	Resa *	Capacity *	Puissance *	Leistung *	Rendimiento *	
CMP	W	6,48	Pot. nom. assorbita	Nom. power cons.	Puiss. nom. absorbée	Nennleistungsaufnahme	Pot. nominal absorbida
	CV	3,0	Potenza nominale	Power rating	Puissance nominale	Nennleistung	Potencia nominal
		S	Tipo compressore	Compressor type	Type compresseur	Kompressortyp	Tipo compresor
CND	mm	2,5	Passo alette	Fin spacing	Ecart alettes	Lamellenabstand	Paso aletas
		3 x Ø250	Ventilatori	Fan	Ventilateur	Ventilator	Ventiladores
	W	285	Pot. nom. assorbita	Nom. power cons.	Puiss. nom. absorbée	Nennleistungsaufnahme	Pot. nominal absorbida
	m ³ /h	2100	Portata aria	Air volume	Debit d' air	Volumenstrom	Caudal aire
EVP	mm	8,5	Passo alette	Fin spacing	Ecart alettes	Lamellenabstand	Paso aletas
		EL	Sbrinamento	Defrost	Dégivrage	Abtauung	Descongelación
		VT	Espansione	Expansion	Expansion	Expansion	Expansión
		2 x Ø315	Ventilatori	Fan	Ventilateur	Ventilator	Ventiladores
	W	190	Pot. nom. assorbita	Nom. power cons.	Puiss. nom. absorbée	Nennleistungsaufnahme	Pot. nominal absorbida
	m ³ /h	3270	Portata aria	Air volume	Debit d' air	Volumenstrom	Caudal aire
	m	16	Freccia d' aria	Air throw	Projection d'air	Reichweite	Flecha de aire
kg	173	Peso netto	Net Weight	Poids net	Nettogewicht	Peso neto	
kg	220	Peso lordo	Gross weight	Poids brut	Bruttogewicht	Peso bruto	
	111103523	Codice	Code	Code	Kodex	Codigo	

* = -30°C / +40°C BT

KS		EVAPORATORE		
1470	X	-	X	Imballi Packing
800	Y	-	Y	Emballage Verpackung
1265	Z	-	Z	Embalajes

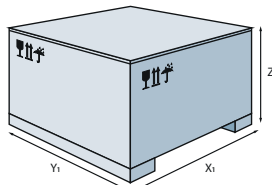

C : Capillare / Capillary / Capillaire / Kapillar / Capilar
 CMP : Compressore / Compressor / Compresseur / Kompressorleistung / Compresor
 CND : Condensatore / Condenser / Condenseur / Verflüssiger / Condensador
 E : Ermetico / Hermetic / Hermétique / Völlhermetisch / Hermético
 EVP : Evaporatore / Evaporateur / Evaporateur / Verdampfer / Evaporador
 HG : Gas caldo / Hot gas / Gaz chaud / Heissgas / Gas caliente
 P : Potenza frigorifera / Cooling capacity / Puissances frigorifiques / Kälteleistung
 Potencia frigorífica

S : Semihermetico / Semihermetic / Semi-hermetique / Halbhermetisch / Semihermético
 Ta : Temperatura ambiente / Ambient temperature / Température ambiente
 Umgebungstemperatur / Temperatura ambiente
 Tc : Temperatura cella / Cold room temperature / Température chambre froid
 Kühlraumtemperatur / Temperatura cámara
 V : Volume cella / Coldroom volume / Volume chambre / Kühlzellenvolumen / Volumen cámara
 VT : Valvola termostatica / Expansion valve / Détendeur thermostatique / Thermostatisches
 Expansionventil / Válvula termostática

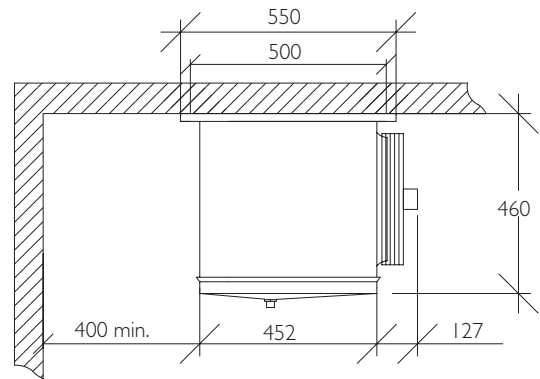
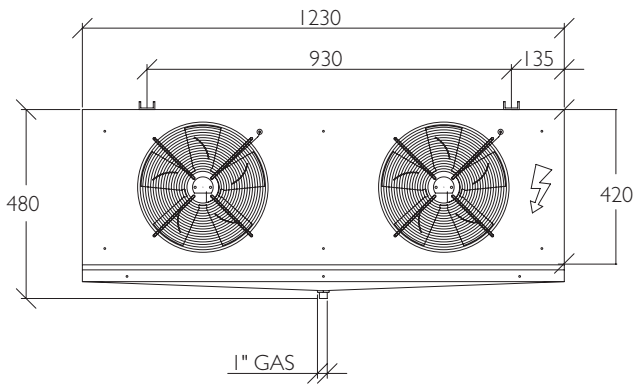
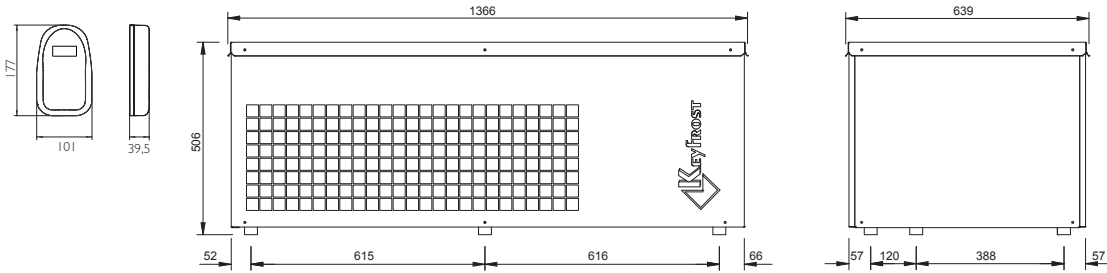

RESA - CAPACITY - PUISSANCE - LEISTUNG - RENDIMIENTO / VOLUME - VOLUME - VOLUME - VOLUMEN - VOLUMEN

	Tc [°C]	-20			
	Ta [°C]	27	32	38	43
KS 42 BT S T	P [W]	4225	3815	3379	3001
	V [m3]	89.30	66.50	46.60	33.30