

MINI CREAM 2V LED R600 (COD. E1939S0100)



display

Technical data

Temperature	-10°C -22°C
Voltage and Frequency	230 V~ 50 Hz
Gas	R600a
Net dimension	490 x 790 x 345 mm (l x p x h)
Packed dimension	590 x 890 x 375 mm (l x p x h)
Gross capacity	28 l
Net capacity	20 l
Gross weight	30.00 Kg
Net weight	26.00 Kg
Heat insulation	Rigid polyurethane foam "HCFC/CFC/HFC" free
External cabinet	White prepainted steel sheet
Cabinet bottom	Galvanized steel sheet
Inner tank	Stainless steel - AISI 304 BA
Light tank	Internal light LED
Frame	White thermoformed plastic
Top	Low emissivity glass
Back grid - colour	White plasticised steel rod
Compressor	1/6 HP
absorbed power	95 W
Power consumption (24h)	1,8 kWh/24h
Condensator	Wire and tube - maintenance free with powered fan
Evaporator	Static evaporator wrapping the tank
Defrosting	Manual
Climatic class	4 (30°C-55%RH) L1
Plug	European - Angular Plug
Thermometer	Mechanical
Thermostat	Mechanical
Standard equipment	Basket for stainless steel bins 5-2,5 lt
Optional	Stainless steel bins - Light box kit
Brand	MONDIAL FRAMEC
Producer brand	MONDIAL FRAMEC

MINI CREAM 2V LED R600 (COD. E1939S0100)



display

Layout

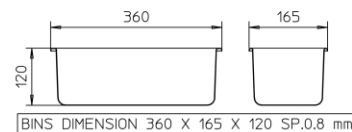
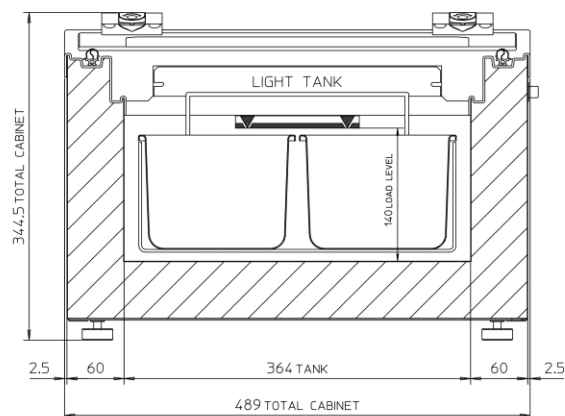
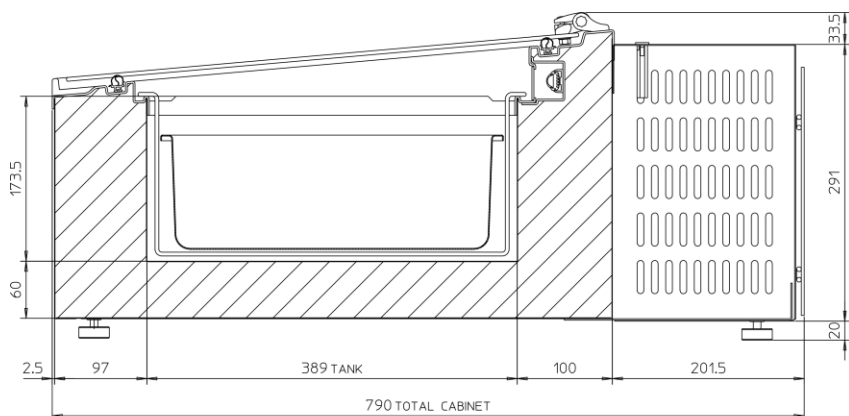

TDA = 0.147 m²

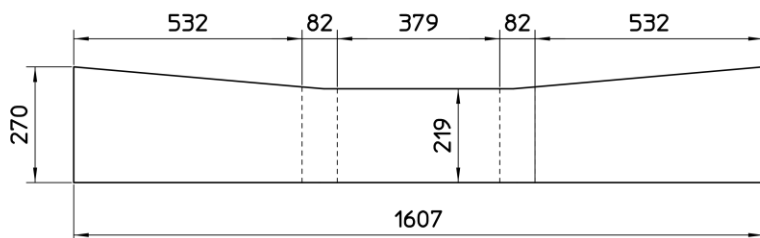
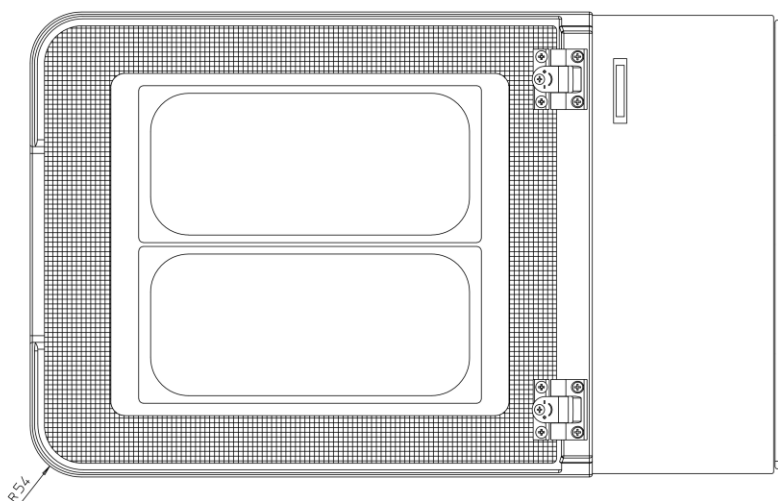

CUSTOMIZATION AREA

MINI CREAM 2 V

S_46233 - 00