

KBS

SERIE TETTO
ROOF SERIES
SÉRIE PLAFOND
DECKENSERIE
SERIE TECHO

18 BT E M
18 BT E T
27 BT E T

	KBS 18 BT E M	KBS 18 BT E T	KBS 27 BT E T	Modello	Model	Modèle	Modell	Modelo		
°C	-18 ÷ -22	-18 ÷ -22	-18 ÷ -22	Campo applicazione	Application field	Champe d'application	Anwendungsbereich	Campo d'aplicación		
	230V/1/50Hz	400V/3/50Hz	400V/3/50Hz	Alimentazione	Power supply	Alimentation	Netzanschluß	Alimentación		
A	13,1	6,3	7,6	Corrente max. assorbita	Max. absorbed current	Courant absorbé max.	Max. absorbierter Strom	Corriente máx. absorbida		
kW	2,8	2,8	3,6	Potenza max. assorbita	Max. absorbed power	Puissance max. absorbée	Max. aufgenommene Leistung	Máx. potencia absorbida		
	R452A	R452A	R452A	Tipo refrigerante	Refrigerant type	Tipe du gaz	Kältemittel	Tipo refrigerante		
W	1318	1318	1772	Resa *	Capacity *	Puissance *	Leistung *	Rendimiento *		
CMP	CV	1.9	1.9	2.4	Potenza nominale	Power rating	Puissance nominale	Nennleistung	Potencia nominal	
		E	E	E	Tipo compressore	Compressor type	Type compresseur	Kompressortyp	Tipo compresor	
CND	mm	2.5	2.5	2.5	Passo alette	Fin spacing	Ecart alettes	Lamellenabstand	Paso aletas	
		2 x Ø 254	2 x Ø 254	2 x Ø 254	Ventilatori	Fan	Ventilateur	Ventilator	Ventiladores	
	W	146	146	146	Pot. nom. assorbita	Nom. power cons.	Puiss. nom. absorbée	Nennleistungsaufnahme	Pot. nominal absorbida	
	m ³ /h	1500	1500	1500	Portata aria	Air volume	Debit d' air	Volumenstrom	Caudal aire	
EVP	mm	4.2	4.2	4.2	Passo alette	Fin spacing	Ecart alettes	Lamellenabstand	Paso aletas	
		HG	HG	HG	Sbrinamento	Defrost	Dégivrage	Abtauung	Descongelación	
		VT	VT	VT	Espansione	Expansion	Expansion	Expansion	Expansión	
		2 x Ø 254	2 x Ø 254	2 x Ø 254	Ventilatori	Fan	Ventilateur	Ventilator	Ventiladores	
	W	146	146	146	Pot. nom. assorbita	Nom. power cons.	Puiss. nom. absorbée	Nennleistungsaufnahme	Pot. nominal absorbida	
		m ³ /h	1400	1400	1400	Portata aria	Air volume	Debit d' air	Volumenstrom	Caudal aire
	m	6	6	6	Freccia d' aria	Air throw	Projection d'air	Reichweite	Flecha de aire	
kg	115	115	125	Peso netto	Net Weight	Poids net	Nettogewicht	Peso neto		
kg	161	161	171	Peso lordo	Gross weight	Poids brut	Bruttogewicht	Peso bruto		
	111107669	111107670	111107666	Codice	Code	Code	Kodex	Codigo		

*= -30°C / +40°C BT

mm	980	X	Imballi Packing
mm	1320	Y	Emballage Verpackung
mm	730	Z	Embalajes

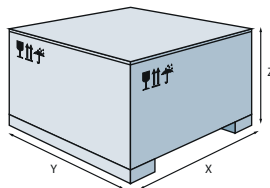

C : Capillare / Capillary / Capillaire / Kapillar / Capilar
 CMP: Compressore / Compressor / Compresseur / Kompressorleistung / Compresor
 CND: Condensatore / Condenser / Condenseur / Verflüssiger / Condensador
 E : Ermetico / Hermetic / Hermetique / Vollhermetisch / Hermético
 EVP: Evaporatore / Evaporateur / Evaporateur / Verdampfer / Evaporador
 HG : Gas caldo / Hot gas / Gaz chaud / Heissgas / Gas caliente
 P : Potenza frigorifera / Cooling capacity / Puissances frigorifiques / Kälteleistung
 Potencia frigorífica

S : Semiermetico / Semihermetic / Semi-hermetique / Halbhermetisch / Semihermético
 Ta : Temperatura ambiente / Ambient temperature / Température ambiente
 Umgebungstemperatur / Temperatura ambiente
 Tc : Temperatura cella / Cold room temperature / Température chambre froid
 Kühlraumtemperatur / Temperatura cámara
 V : Volume cella / Coldroom volume / Volume chambre / Kühlzellenvolumen / Volumen cámara
 VT : Valvola termostatica / Expansion valve / Détendeur thermostatique / Thermostatisches
 Expansionsventil / Válvula termostática

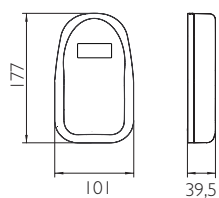
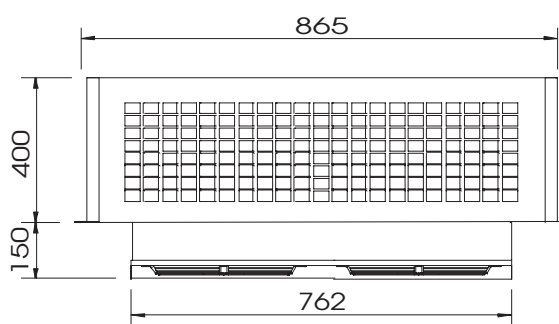
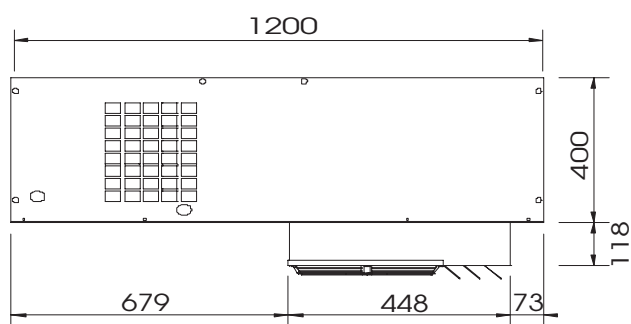

RESA - CAPACITY - PUISSANCE - LEISTUNG - RENDIMIENTO / VOLUME - VOLUME - VOLUME - VOLUMEN - VOLUMEN

		-20				
		Tc [°C]				
		Ta [°C]	27	32	38	43
KBS 18 BT E M	P [W]	1684	1533	1375	1206	
	V [m3]	24.57	18.46	13.01	8.63	
KBS 18 BT E T	P [W]	1640	1519	1357	1182	
	V [m3]	24.38	18.50	12.73	8.62	
KBS 27 BT E T	P [W]	2006	1892	1686	1482	
	V [m3]	32.31	25.15	17.47	11.85	