



Modular ice maker - Pebble system Daily production up to 140 kg

Hotel	████████████████████
Restaurant	████████████████████
Fast food	████████████████████
Bar	████████████████████
Disco	████████████████████
Fish market	████████████████████
Supermarket	████████████████████
Medical & SPA	████████████████████
Industry	████████████████████

► Position n°



► Features & Plus

- Pebble ice - 91% dry
- 1l (water) - 1kg (ice) - only Air cooled
- AISI 304 SS Scotch Brite finish
- Tropical class +43°C
- Specific volume 1 m³ = 550 kg of ice
- Removable and cleanable air filter
- AISI 304 SS evaporator
- Air or water cooling system
- Easy cleanable internal rounded surfaces
- Dust-proof water basin
- RoHS Free
- Electromechanical operation
- ON-OFF rocker switch
- Automatic water charge
- Standard and special voltages
- Frame in INOX
- HFC Free



► Usable Bins

- Bin 240PE
- Bin 110
- Bin 200
- Roller Bin 100



Removable and cleanable air filter



AISI 304 SS evaporator



Dust-proof water basin



Frame in INOX

► Available pebble size

drawing for reference only

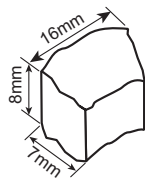

► Prod. 24h

Air temp.	Water temp.		Kg	Lbs
	10° C	50° F		
10° C	50° F	7° C	140	309
21° C	70° F	15° C	130	287

► Certifications available for this model





Ice Pebbles

TM 140 HC



Modular ice maker - Pebble system Daily production up to 140 kg

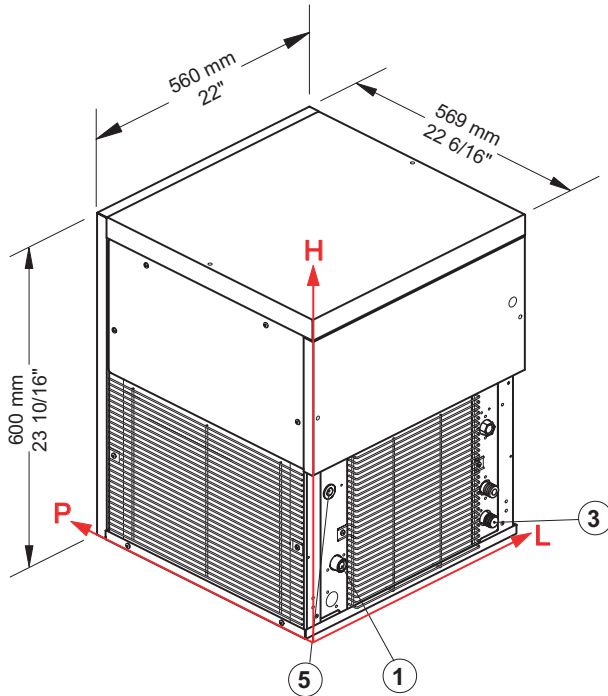

► Working conditions

- Location: **Indoor**

	Min	Max
Ambient temperature	+10° C / +50° F	+43° C / 110° F
Water temperature	+3° C / +37° F	+32° C / +90° F
Voltage	-10%	+10%
Water inlet pressure	1bar (14 psi)	6bar (84 psi)

► Performances

	Air temperature	Water temperature	Water temperature				
			7° C	45° F	15° C	60° F	21° C
	10° C	140 kg					
	50° F	309 lbs					
	21° C		130 kg				
	70° F			287 lbs			
	32° C				119 kg		
	90° F					262 lbs	

► Connections

All measures are referred to the down-left corner (L-H-Ø)

- ① Water in.: 85,5 mm / 3 6/16" - 130 mm / 5 2/16" - 3/4"
- ③ Water out.: 479,5 mm / 18 14/16" - 65 mm / 2 9/16" - 24 mm / 15/16"
- ⑤ Electrical connections: 67,5 mm / 2 11/16" - 290 mm / 11 7/16"

► Technical information

Production in 24h	130 kg / 287 lbs	Water consumption	A: 1 l/kg - 12,0 gal/100 lbs W: 7,4 l/kg - 88,7 gal/100 lbs
Cooling system	A - W	Sizes (L-P-H mm)	560 - 569 - 600
Approximate pebble size	8 x 16 x 7	(L-P-H in)	22 - 22 6/16 - 23 10/16
Refrigerant	R290	Sizes with pack (L-P-H mm)	645 - 645 - 810
Standard voltage	220-240 V ~ 50 Hz	(L-P-H in)	25 6/16 - 25 6/16 - 31 14/16
Average power consumption	700 W	Net weight	63 kg / 139 lbs
Fuse	10 A	Gross weight	74 kg / 163 lbs
Electrical consumption	13 kWh/100kg	Finish	AISI 304 stainless steel, scotch brite

All the technical information need to be considered at the following conditions:

- Ambient temperature +21° C
- Water temperature +15° C
- Electrical consumption at +32° C (standard voltage)
- Average power consumption at +43° C (standard voltage)

Models and specifications are subject to change without notice

Rev. 01.1 - Issued November 2018



www.bremaice.it
info@bremaice.it

Bim + Data
download

