

Modular ice maker - Vertical evaporator system Daily production up to 145 kg

Hotel	████████████████████
Restaurant	████████████████████
Fast food	████████████████████
Bar	████████████████████
Disco	████████████████████
Fish market	████████████████████
Supermarket	████████████████████
Medical & SPA	████████████████████
Industry	████████████████████

► Position n°



► Features & Plus

- Single and crystal cube
- AISI 304 SS Scotch Brite finish
- Tropical class +43°C
- Removable and cleanable air filter
- Air or water cooling system
- Easy cleanable internal rounded surface
- RoHS Free
- Electromechanical operation
- ON-OFF rocker switch
- Automatic washing system
- Standard and special voltages



Single and crystal cube



AISI 304 SS Scotch Brite finish



Removable and cleanable air filter

► Usable Bins

- Bin 110
- Bin 200
- Bin 240PE

► Available ice cube size

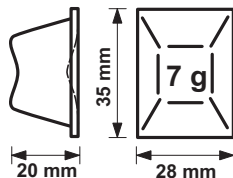

► Prod. 24h

Air temp.	Water temp.		Kg	Lbs
	10° C	50° F		
10° C	50° F	7° C	145	320
21° C	70° F	15° C	140	309

► Certifications available for this model



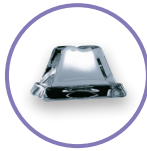

Fast Ice

VM 350



Modular ice maker - Vertical evaporator system Daily production up to 145 kg

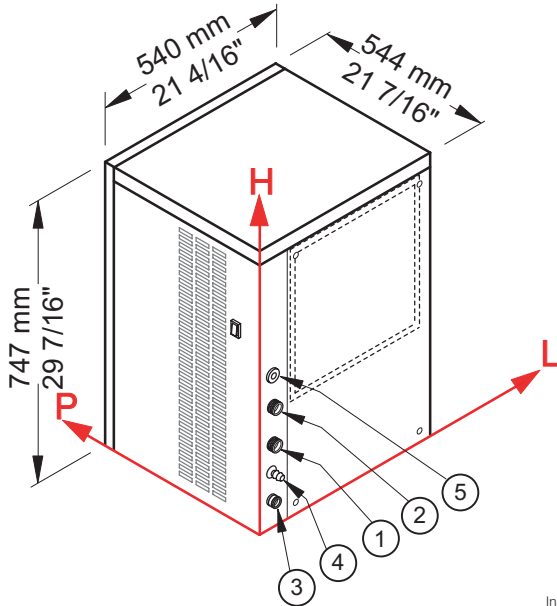

► Working conditions

- Location: **Indoor**

	Min	Max
Ambient temperature	+10° C / +50° F	+43° C / 110° F
Water temperature	+3° C / +37° F	+32° C / +90° F
Voltage	-10%	+10%
Water inlet pressure	1bar (14 psi)	6bar (84 psi)

► Performances

	Air temperature	Water temperature	Water temperature					
			7° C	45° F	15° C	60° F	21° C	70° F
	10° C	145 kg						
	50° F	320 lbs						
	21° C			140 kg				
	70° F			309 lbs				
	32° C					113 kg		
	90° F						249 lbs	

► Connections

All measures are referred to the down-left corner (L-H-Ø)

- ① Water in.: 35 mm / 1 6/16" - 173 mm / 6 13/16" - 3/4"
- ② Cond. water in.: 35 mm / 1 6/16" - 268 mm / 10 9/16" - 3/4"
- ③ Water out.: 32 mm / 1 4/16" - 42 mm / 1 10/16" - 24 mm / 15/16"
- ④ Cond. water out.: 28 mm / 1 2/16" - 93 mm / 3 11/16" - 12 mm / 8/16"
- ⑤ Electrical connections: 33 mm / 1 5/16" - 343 mm / 13 8/16"
- ② ④ Only water cooling systems

► Technical information

Production in 24h	140 kg / 309 lbs	Water consumption	A: 3 l/kg - 35,9 gal/100 lbs
Cooling system	A - W		W: 13,5 l/kg - 161,8 gal/100 lbs
Kind of cube	7g	Sizes (L-P-H mm)	540 - 544 - 747
Refrigerant	R404A - R452A	(L-P-H in)	21 4/16 - 21 7/16 - 29 7/16
Standard voltage	220-240 V ~ 50 Hz	Sizes with pack (L-P-H mm)	580 - 615 - 925
Average power consumption	1400 W	(L-P-H in)	22 13/16 - 24 3/16 - 36 7/16
Fuse	16 A	Net weight	73 kg / 161 lbs
Finish	AISI 304 stainless steel, scotch brite	Gross weight	83 kg / 183 lbs

All the technical information need to be considered at the following conditions:
 Standard Cube (7 g)
 Ambient temperature +21° C
 Water temperature +15° C
 Average power consumption at +43° C (standard voltage)
 Refrigerant R404A

Models and specifications are subject to change without notice

Rev. 03 - Issued May 2018



www.bremaice.it
info@bremaice.it

