



Modular ice maker - Scale system Daily production up to 915 kg

Hotel	████████████████████
Restaurant	████████████████████
Fast food	████████████████████
Bar	████████████████████
Disco	████████████████████
Fish market	████████████████████
Supermarket	████████████████████
Medical & SPA	████████████████████
Industry	████████████████████

► Position n°



► Features & Plus

- Sub-cooled scale ice 99% dry
- 1l (water) - 1kg (ice) - only Air cooled
- AISI 304 SS Scotch Brite finish
- Tropical class +43°C
- Specific volume 1 m³ = 430 kg of ice
- Vertical fixed "no leak" evaporator
- AISI 316L SS evaporator
- Removable and cleanable air filter
- Cleanable antiscaling filter
- Air or water cooling system
- FDA approved - ABS plastic components
- Easy cleanable internal rounded surfaces
- RoHS Free
- Electromechanical operation
- Automatic water charge
- Standard and special voltages
- Frame in INOX



Vertical fixed "no leak" evaporator



Removable and cleanable air filter



Cleanable antiscaling filter



Frame in INOX

► Usable Bins

- Bin 350
- Bin 550V DS
- Double Roller Bin 500
- Double Roller Bin 1200

► Prod. 24h

Air temp.	Air temp.		Water temp.		Kg	Lbs
	7° C	45° F	10° C	50° F		
7° C	45° F	10° C	50° F	915	2017	
21° C	70° F	15° C	60° F	900	1984	

► Certifications available for this model





Ice Scales

Muster 800



Modular ice maker - Scale system Daily production up to 915 kg

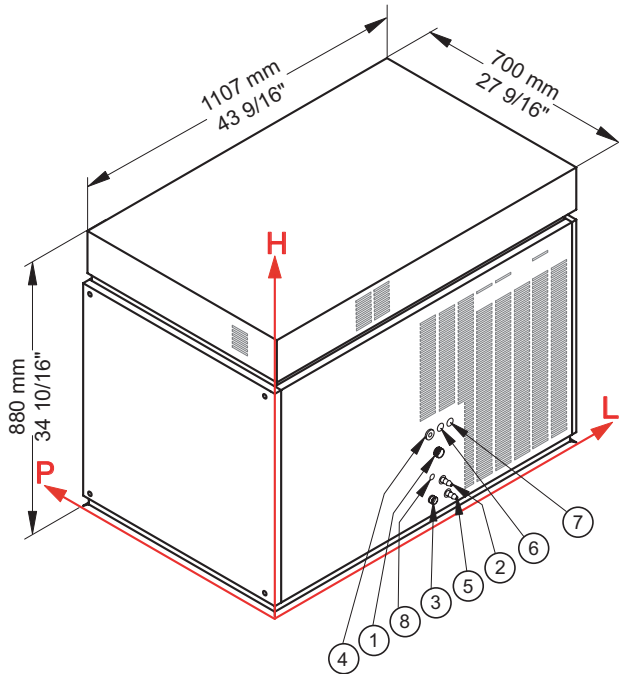

► Working conditions

- Location: **Indoor**

	Min	Max
Ambient temperature	+10° C / +50° F	+43° C / 110° F
Water temperature	+3° C / +37° F	+32° C / +90° F
Voltage	-10%	+10%
Water inlet pressure	1bar (14 psi)	6bar (84 psi)

► Performances

	Air temperature	Water temperature	Water temperature					
			7° C	45° F	15° C	60° F	21° C	70° F
	10° C	915 kg						
	50° F	2017 lbs						
	21° C		900 kg					
	70° F			1984 lbs				
	32° C				790 kg			
	90° F					1742 lbs		

► Connections

All measures are referred to the down-left corner (L-H-Ø)

- ① Water in.: 563 mm / 22 3/16" - 192 mm / 7 9/16" - 3/4"
- ② Cond. water in.: 563 mm / 22 3/16" - 125 mm / 4 15/16" - 12 mm / 8/16"
- ③ Water out.: 528 mm / 20 13/16" - 65 mm / 2 9/16" - 24 mm / 15/16"
- ④ Electrical connections: 532 mm / 20 15/16" - 262 mm / 10 5/16"
- ⑤ Cond. water out.: 573 mm / 22 9/16" - 65 mm / 2 6/16" - 12 mm / 8/16"
- ⑥ Remote connections.: 574 mm / 22 10/16" - 262 mm / 10 5/16"
- ⑦ Connection to DRB 500: 608 mm / 24 15/16" - 262 mm / 10 5/16"
- ⑧ Connection to feed pump: 515 mm / 20 5/16" - 159 mm / 10 5/16"
- ② ③ Only for water cooling systems

► Technical information

Production in 24h	900 kg / 1984 lbs
Cooling system	A - W
Refrigerant	R404A - R452A
Standard voltage	400-415 V ~ 3N 50 Hz
Electrical consumption	4600 W
Fuse	16 A
Water consumption	A: 1 l/kg - 12,0 gal/100 lbs W: 6,9 l/kg - 82,7 gal/100 lbs

Sizes (L-P-H mm)	1107 - 700 - 880
(L-P-H in)	43 9/16 - 27 9/16 - 34 10/16
Sizes with pack (L-P-H mm)	1210 - 800 - 1095
(L-P-H in)	47 10/16 - 31 8/16 - 43 2/16
Net weight	241 kg / 531 lbs
Gross weight	262 kg / 578 lbs
Finish	AISI 304 stainless steel, scotch brite

All the technical information need to be considered at the following conditions:
 Ambient temperature +21° C
 Water temperature +15° C
 Electrical consumption at +43° C (standard voltage)
 Refrigerant R404A

Models and specifications are subject to change without notice

Rev. 03b - Issued May 2018



www.bremaice.it
info@bremaice.it

Bim + Data
download

