



VM 500

LIST OF THE EXPLODED VIEWS

From s/n. 297566 up Today

From s/n.141196 till s/n. 297565



SHELL ASSY

COOLING SYSTEM

HYDRAULIC CIRCUIT

SPRAYER PUMP

ELECTRIC PARTS



SHELL ASSY

COOLING SYSTEM

HYDRAULIC CIRCUIT

SPRAYER PUMP

ELECTRIC PARTS

Rev. 8 - 22/06/2011

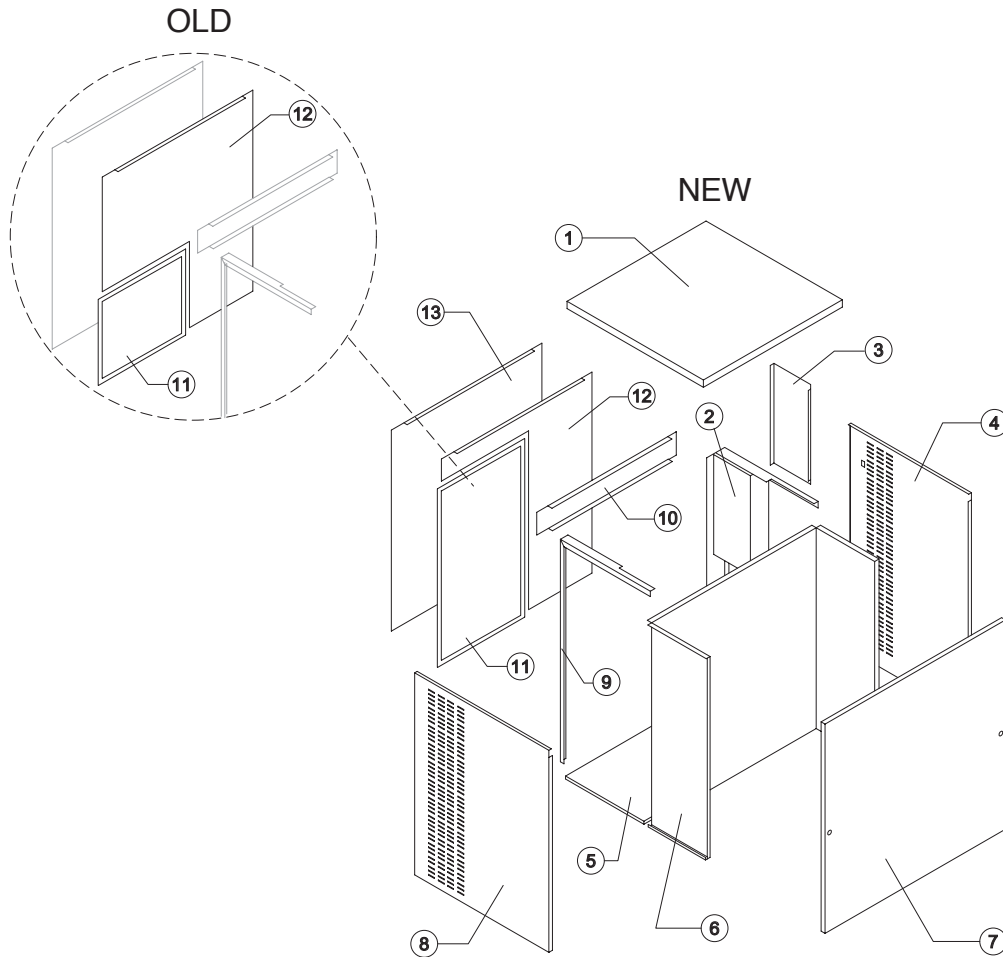

Common Parts

Ref.	Spare Description	Code
1	Top Assembly	C22813
2	Right Angle Bar	22814
3	Electrical Box Cover	21323
4	Right Side Panel	22408
5	Base Plate	22812
6	Evaporator Chamber	22819
7	Front Panel Assembly	C22816
8	Left Side Panel	22822
9	Left Angle Bar	22820
10	Rear Cross Bar	22817

Parts for Air-Cooled Version Only

Ref.	Spare Description	Code
11*	Filter	See Table -
12	Rear Panel	See Table -

Parts for Water-Cooled Version Only

Ref.	Spare Description	Code
13	Rear Panel	21285

Ref. 11 - Filter

Version	Code
NEW	18178
OLD	18163

Ref. 12 - Rear Panel

Version	Code
NEW	21324
OLD	21286



VM 500

From s/n. 297566 up Today

COOLING SYSTEM

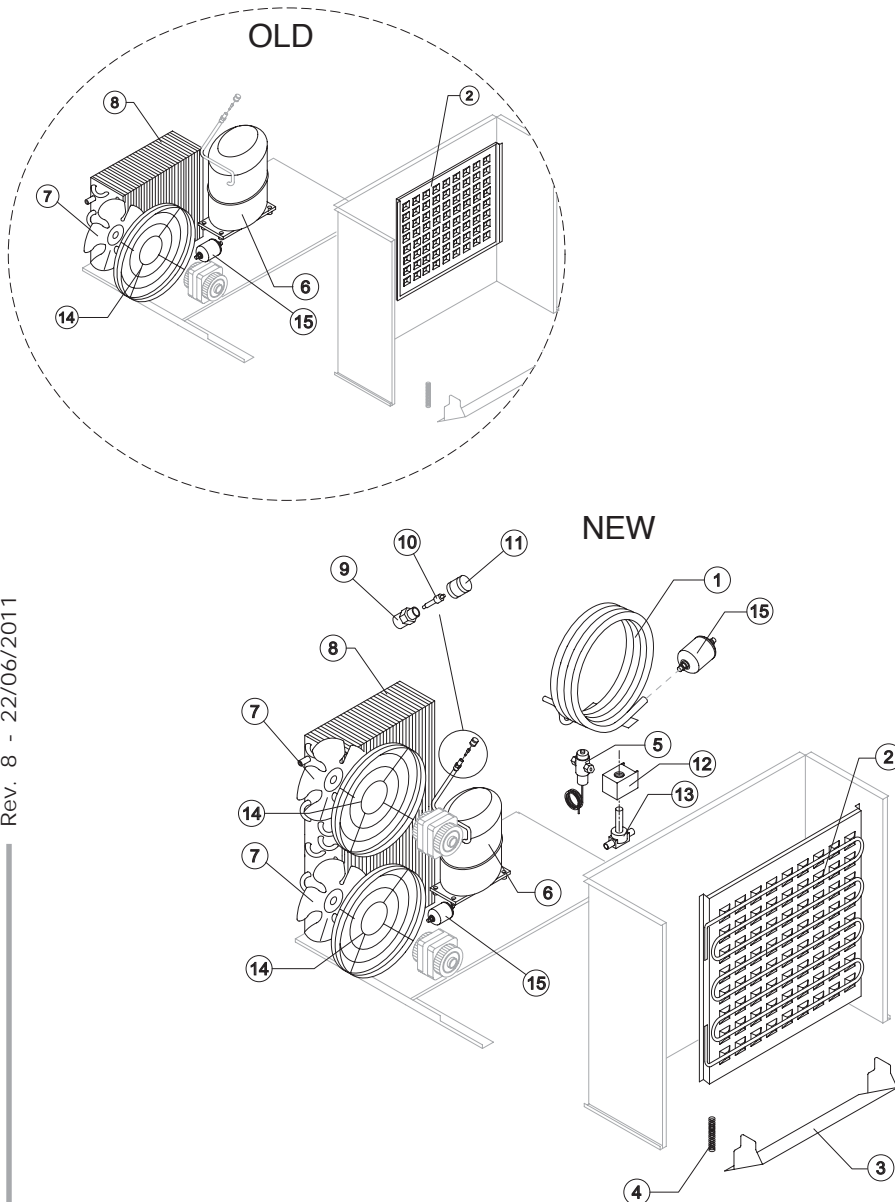

Common Parts

Ref.	Spare Description	Code
2	Evaporator	See Table
3	Horizontally Hinged Panel	22608
4	Spring	20464
6	Compressor	See Table
9	Vacuum-Charge Valve Body	14007
10*	Vacuum-Charge Valve Device	14005
11*	Vacuum-Charge Valve Plug	14006
12*	Hot Gas Valve Coil	See Table
13*	Hot Gas Valve Body	20409
15*	Liquid Line Drier	14084

Parts for Air-Cooled Version Only

Ref.	Spare Description	Code
7	Sucking Fan	See Table
8	Air Condenser	See Table
14	Fan Motor Grid	12054

Parts for Water-Cooled Version Only

Ref.	Spare Description	Code
1	Water Condenser	14081
5	Pressostatic Valve	20210

Ref. 1 - Evaporator

Version	Code
NEW	D10228
OLD	D10227

Ref. 6 - Compressor

Voltage	NEW	OLD
T11	23840	23543
T12	23897	23642
T18	23642	23642

Ref. 7 - Sucking Fan

Voltage	Code
NEW	20153
OLD	20407

Ref. 8 - Air Condenser

Voltage	Code
NEW	20406
OLD	20670

Ref. 12* - Hot Gas Valve Coil

Voltage	Code
T11	23091
T12	23091
T18	23843

Rev. 8 - 22/06/2011



VM 500

From s/n. 297566 up Today

SPRAYER PUMP

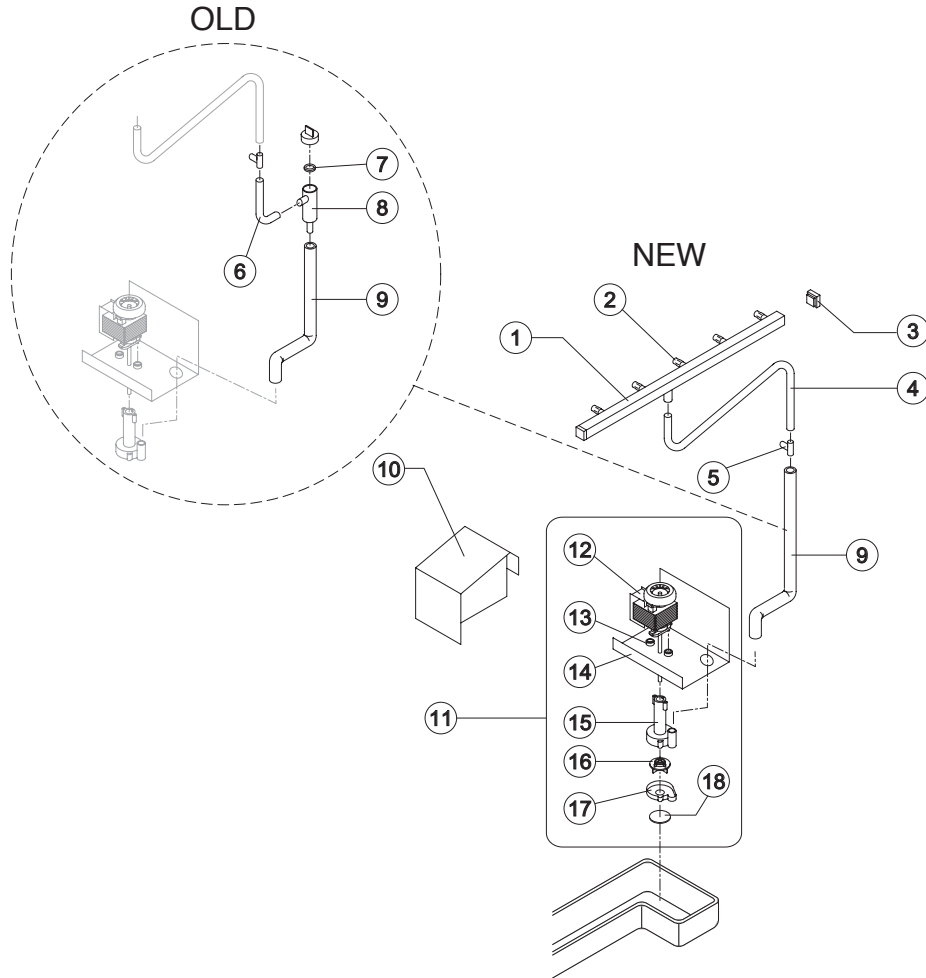

Ref.	Spare Description	Code
1*	Sprayers Bar Assembly	C20465
2	Sprayer	D20002
3	Sprayers Bar Plug	10012
4	Sprinkler Bar Connecting Pipe ("T" Shaped)	13134
5	Plastic "T" ø 20	10082
6	Sprayers Feeding Pipe	OLD version 13005
7	Pump Filter Gasket	OLD version 13080
8	Pump Filter	OLD version 10139
9	"T" - Pump Connection Pipe	See Table -
10	Protection Pump Panel	22804
11*	Pump Assembly	See Table -
12	Pump	See Table -
13	Pump Motor Shim	20510
14	Pump Motor Support	22799
15	Pump Body	10065
16	Pump Impeller	See Table -
17	Diffusor	10067
18	Pump Filter	20518

Ref. 9 - "T" - Pump Connection Pipe

Version	Code
NEW	13113
OLD	13157

Ref. 11* - Pump Assy

Voltage	Code
T11	C23624
T12	C23616
T18	C23616

Ref. 12 - Pump

Voltage	Code
T11	23073
T12	23187
T18	23187

Ref. 16 - Pump Impeller

Voltage	Code
T11	10066
T12	10138
T18	10138

Rev. 8 - 22/06/2011



VM 500

From s/n. 297566 up Today

ELECTRIC PARTS

OLD

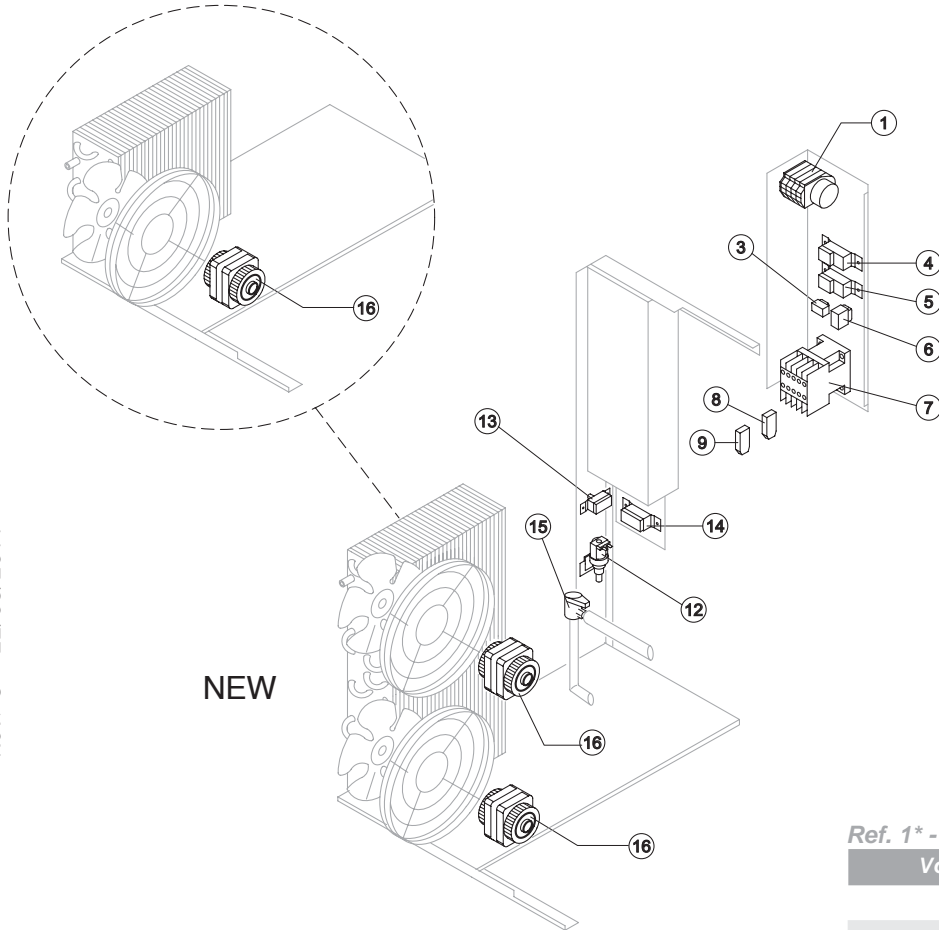

Common Parts

Ref.	Spare Description	Code
1*	Timer	See Table
3	“Cleaning” Switch	23619
4*	Bin Thermostat	R23005
5*	Evaporator Thermostat	R23597
6*	Green Light Switch (On-Off)	23327
7*	Contactor	See Table
12*	1 Way- Water Inlet Valve	23787
13	Safety Pressure Switch	23342
15*	Water Outlet Valve	23537

Parts for Air-Cooled Version Only

Ref.	Spare Description	Code
8	Anti Radio Interference Filter	Only T11 C23459
9	Anti Radio Interference Filter	Only T11 C23458
14*	Condenser Pressure Switch	See Table
16*	Fan Motor	23121

Ref. 1* - Timer

Voltage	Codice
T11	23635
T12	23632
T18	23632

Ref. 7* - Contactor

Voltage	Code
T11	23147
T12	23963
T18	23963

Ref. 14* - Cond. Pressure Switch

Voltage	Code
T11	23175
T12	23175
T18	23680

Rev. 8 - 22/06/2011

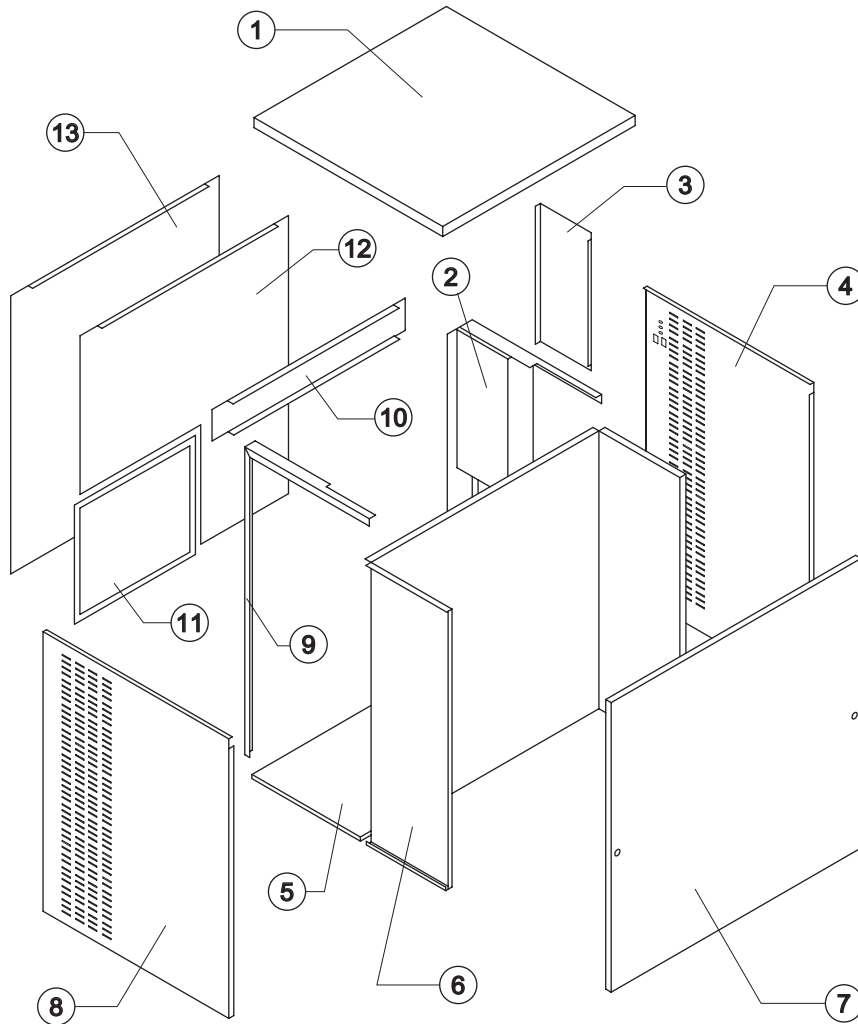

Rev. 8 - 22/06/2011

Common Parts

Ref.	Spare Description	Code
1	Top Assembly	C22813
2	Right Angle Bar	22814
3	Electrical Box Cover	21274
4	Right Side Panel	22821
5	Base Plate	22812
6	Evaporator Chamber	22819
7	Front Panel Assembly	C22816
8	Left Side Panel	22822
9	Left Angle Bar	22820
10	Rear Cross Bar	22817

Parts for Air-Cooled Version Only

Ref.	Spare Description	Code
11	Filter	18163
12	Rear Panel	21286

Parts for Water-Cooled Version Only

Ref.	Spare Description	Code
13	Rear Panel	21285



Common parts

Ref.	Spare Description	Code
2	Evaporator	D10227
3	Horizontally Hinged Panel	22608
4	Spring	20464
6	Compressor	See Table
9	Vacuum-Charge Valve Body	14007
10	Vacuum-Charge Valve Device	14005
11	Vacuum-Charge Valve Plug	14006
12	Hot Gas Valve Coil	See Table
13	Hot Gas Valve Body	20409

Parts for Air-Cooled Version Only

Ref.	Spare Description	Code
7	Sucking Fan	20407
8	Air Condenser	20670
14	Fan Motor Grid	12056

Parts for Water-Cooled Version Only

Ref.	Spare Description	Code
1	Water Condenser	14081
5	Pressostatic Valve	20210

Ref. 6 - Compressor

Voltage	Code
T11	23543
T12	23642
T18	23642

Rif. 12- Bobina Valv. Inv. Ciclo

Voltage	Code
T11	23091
T12	23091
T18	23843

Rev. 8 - 22/06/2011

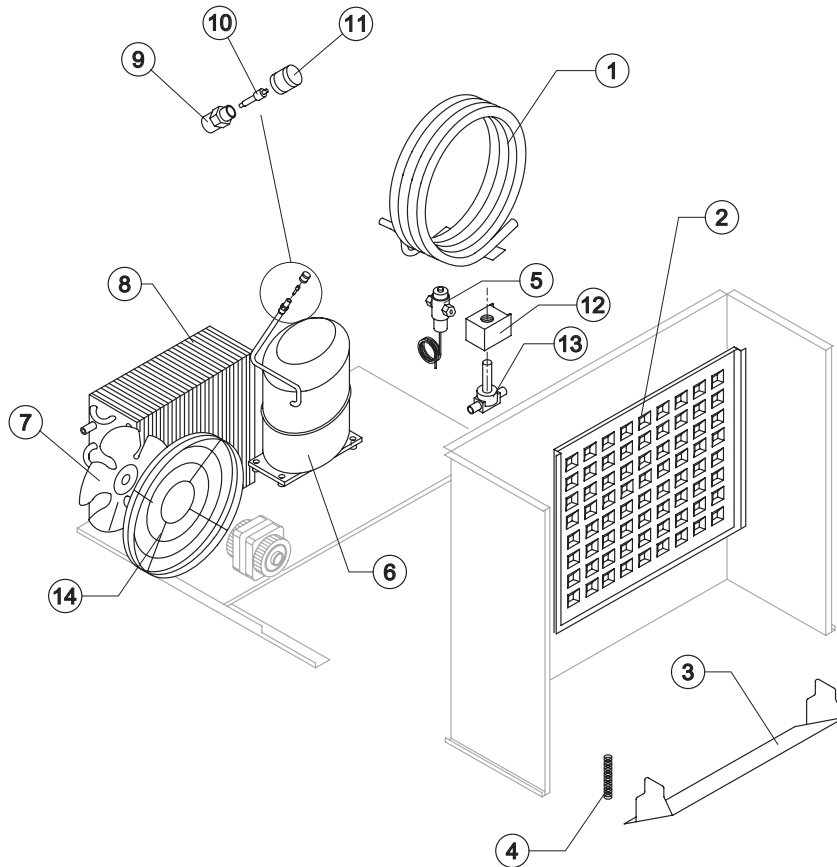



Common parts

Ref.	Spare Description	Code
1	Overflow Pipe	10133
2	OR Gasket for Overflow Pipe	20233
3	Overflow Pipe Nipple	10241
4	Silicone Gasket	13006
5	Semirigid Polyethylene Gasket	13007
6	Bin Discharge Nut	10096
7	Water Basin	10395
8	Ice Cubes Slide	D12057
10	Overflow Pipe Nipple	13120
11	Drain Nipple	10431
12	Discharge Valve Connection Pipe - Discharge	13040
13	Discharge Valve Connection Pipe ("T" Shaped)	13102

Parts for Water-Cooled Version Only

Ref.	Spare Description	Code
9	Connection with Plate	C20462

Rev. 8 - 22/06/2011

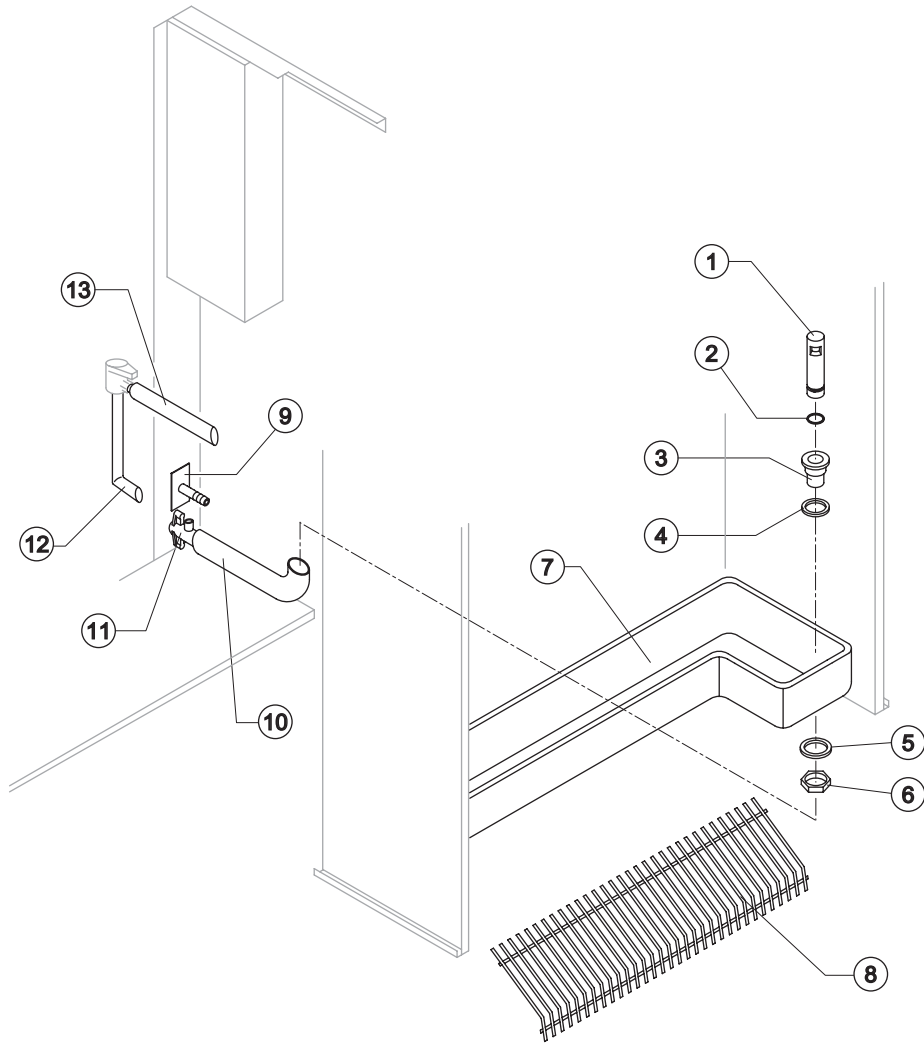



VM 500

From s/n. 141196 till s/n. 297565

SPRAYER PUMP

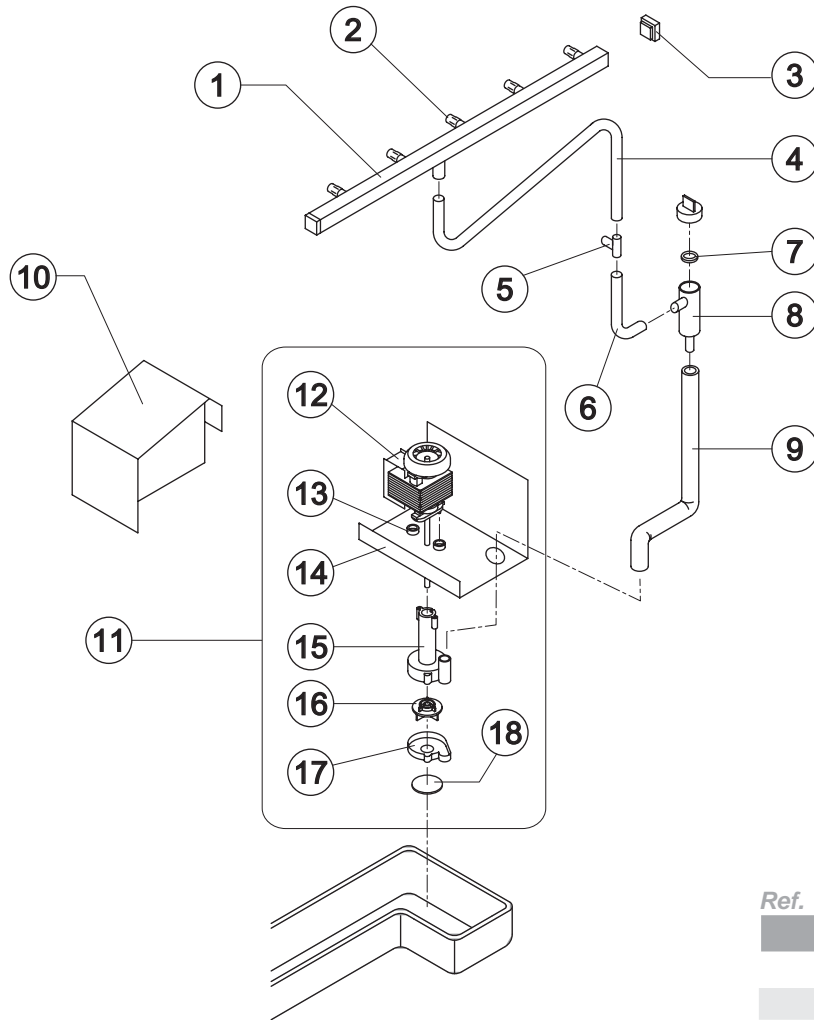

Ref.	Spare Description	Code	
1	Sprayers Bar Assembly	C20465	
2	Sprayer	D20002	
3	Sprayers Bar Plug	10012	
4	Sprinkler Bar Connecting Pipe ("T" Shaped)	13134	
5	Plastic "T" ø 20	10082	
6	Sprayers Feeding Pipe	13005	
7	Pump Filter Gasket	13080	
8	Pump Filter	10139	
9	"T" - Pump Connection Pipe	13157	
10	Protection Pump Panel	22804	
11	Pump Assembly	See Table	-
12	Pump	See Table	-
13	Thickness Pump Motor		20510
14	Pump Motor Support		22799
15	Pump Body		10065
16	Pump Impeller	See Table	-
17	Diffusor		10067
18	Pump Filter		20518

Ref. 11 - Pump Assy

Voltage	Code
T11	C23624
T12	C23616
T18	C23616

Ref. 12 - Pump

Voltage	Code
T11	23073
T12	23187
T18	23187

Ref. 16 - Pump Impeller

Voltage	Code
T11	10066
T12	10138
T18	10138

Rev. 8 - 22/06/2011

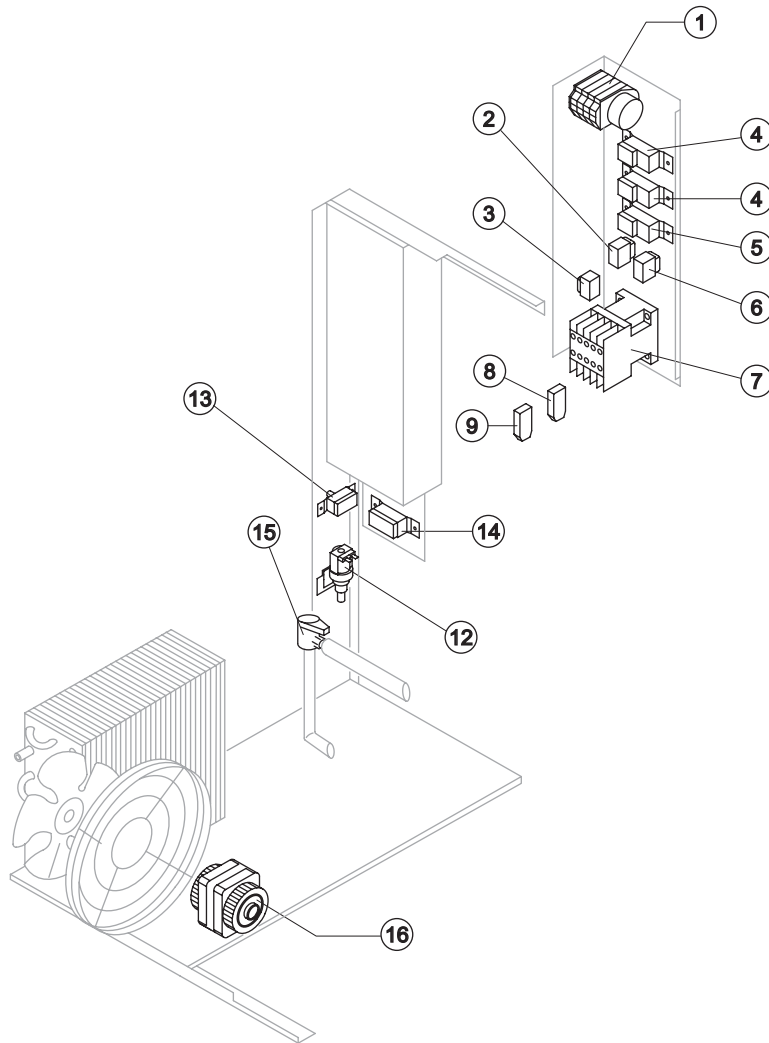

Common parts

Ref.	Spare Description	Code
1	Timer	See Table
2	Light Switch "Economy-Full"	23611
3	"Cleaning" Switch	23619
4	Bin Thermostat	R23005
5	Evaporator Thermostat	R23597
6	Green Light Switch (On-Off)	23327
7	Contactors	See Table
12	1 Way- Water Inlet Valve	23787
13	Safety Pressure Switch	23342
15	Water Outlet Valve	23537

Parts for Air-Cooled Version Only

Ref.	Spare Description	Code
8	Anti Radio Interference Filter	Only T11 C23459
9	Anti Radio Interference Filter	Only T11 C23458
14	Condenser Pressure Switch	See Table -
16	Fan Motor	23121

Ref. 1 - Timer

Voltage	Code
T11	23635
T12	23632
T18	23632

Ref. 7* - Contactor

Voltage	Code
T11	23147
T12	23963
T18	23963

Ref. 14 - Cond. Pressure Switch

Voltage	Code
T11	23175
T12	23175
T18	23680