



Self-contained ice maker - Sprayer system Daily production up to 25 kg

Hotel	████████████████████
Restaurant	██████████████████
Fast food	██████████████
Bar	██████████████████
Disco	██████████████████
Fish market	██████████████
Supermarket	██████████████
Medical & SPA	██████████████
Industry	██████████████

► Position n°



► Features & Plus

- Compact and crystal cube
- AISI 304 SS Scotch Brite finish
- Tropical class +43°C
- Cleanable antiscala filter
- Easy cleanable internal rounded surfaces
- HCFC-Free insulated storage
- RoHS Free
- Disappearing insulated door
- Electromechanical operation
- ON-OFF rocker switch
- Standard and special voltages
- Patented sprayer slide
- Suitable for embedment



AISI 304 SS Scotch Brite finish



Cleanable antiscala filter



Disappearing insulated door



Patented sprayer slide

► Available ice cube size



► Prod. 24h

Air temp.	Water temp.	kg	lbs		
				10° C	50° F
21° C	70° F	15° C	60° F	22	49

► Certifications available for this model





Ice Cube

IC 18

Self-contained ice maker - Sprayer system
Daily production up to 25 kg

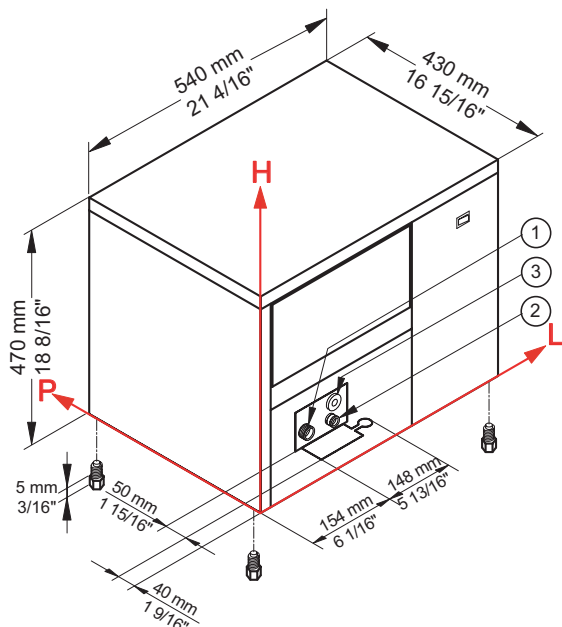
**► Working conditions**

- Location: **Indoor**

	Min	Max
Ambient temperature	+10° C / +50° F	+43° C / 110° F
Water temperature	+3° C / +37° F	+32° C / +90° F
Voltage	-10%	+10%
Water inlet pressure	1bar (14 psi)	6bar (84 psi)

► Performances

	Air temperature	Water temperature	Water temperature				
			7° C	45° F	15° C	60° F	21° C
	10° C	25 kg					
	50° F	55 lbs					
	21° C		22 kg				
	70° F			49 lbs			
	32° C				18 kg		
	90° F					40 lbs	

► Connections

All measures are referred to the rear bottom-left corner

① Water in.: 3/4" Ø

③ Electrical connections

② Water out.: 24 mm / 15/16" Ø

► Technical information

Production in 24h **22 kg / 49 lbs**

Store capacity, up to **4 kg / 9 lbs**

Cooling system **A**

Kind of cube **D-13g**

Refrigerant **R404A - R452A**

Standard voltage **220-240 V ~ 50 Hz**

Average power consumption **320 W**

Fuse **10 A**

Water consumption **A: 4,5 l/kg - 53,9 gal/100 lbs**

Sizes (L-P-H mm) **540 - 430 - 470**

(L-P-H in) **21 4/16 - 16 15/16 - 18 8/16**

Sizes with pack (L-P-H mm) **590 - 490 - 640**

(L-P-H in) **23 4/16 - 19 5/16 - 25 3/16**

Net weight **34 kg / 75 lbs**

Gross weight **39 kg / 86 lbs**

Finish **AISI 304 stainless steel, scotch brite**

All the technical information must be considered at the following conditions:

Sizes without feet

Standard Cube (13 g)

Ambient temperature +21° C

Water temperature +15° C

Average power consumption at +43° C (standard voltage)

Refrigerant R404A

Models and specifications are subject to change without notice

Rev. 03 - Issued May 2018



www.bremaice.it
info@bremaice.it

Bim + Data
download

