



## Undercounter ice maker up to 30 kg - Sprayer system

Hotel	██
Restaurant	██
Fast food	██
Bar	██
Disco	██
Fish market	██
Supermarket	██
Medical & SPA	██
Industry	██

### ► Position n°



### ► Features & Plus

- Compact and crystal cube
- AISI 304 SS Scotch Brite finish
- Tropical class +43°C
- Easy cleanable internal rounded surfaces
- HCFC-Free insulated storage
- RoHS Free
- Disappearing insulated door
- Electromechanical operation
- ON-OFF rocker switch
- Standard and special voltages
- Suitable for embedment



AISI 304 SS Scotch Brite finish



Disappearing insulated door

### ► Available ice cube size

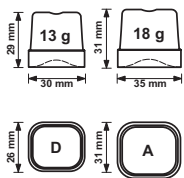

### ► Prod. 24h

Air temp.	Water temp.		kg	lbs	
	10° C	50° F			10° C
10° C	50° F	10° C	50° F	30	66
21° C	70° F	15° C	60° F	26	57

### ► Certifications available for this model





Ice Cube

IC 24



## Undercounter ice maker up to 30 kg - Sprayer system

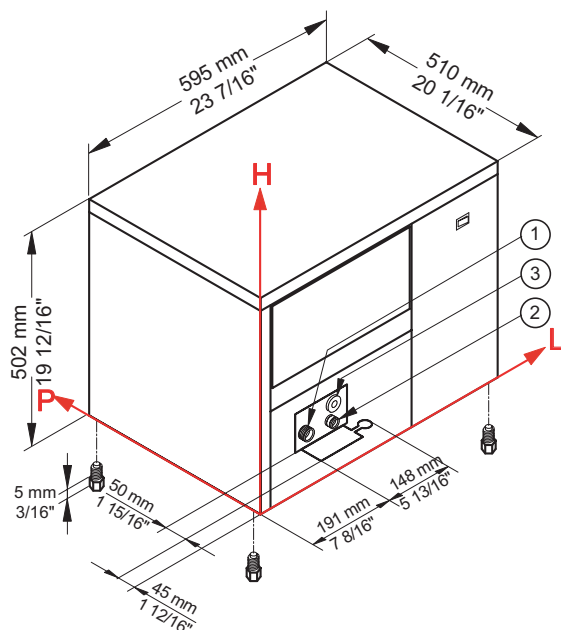

### ► Working conditions

- Location: **Indoor**

	Min	Max
Ambient temperature	+10° C / +50° F	+43° C / 110° F
Water temperature	+3° C / +37° F	+32° C / +90° F
Voltage	-10%	+10%
Water inlet pressure	1bar (14 psi)	6bar (84 psi)

### ► Performances

	Air temperature	Water temperature	Water temperature				
			10° C	50° F	15° C	60° F	21° C
	10° C	30 kg					
	50° F	66 lbs					
	21° C		26 kg				
	70° F			57 lbs			
	32° C				22 kg		
	90° F					49 lbs	

### ► Connections

All measures are referred to the rear bottom-left corner

- ① Water in.: 3/4" Ø
- ③ Electrical connections

② Water out.: 24 mm / 15/16" Ø

### ► Technical information

Production in 24h	26 kg / 57 lbs	Water consumption	A: 5,1 l/kg - 61,1 gal/100 lbs
Store capacity, up to	6 kg / 13 lbs	Sizes (L-P-H mm)	595 - 510 - 502
Cooling system	A	(L-P-H in)	23 7/16 - 20 1/16 - 19 12/16
Kind of cube	A-18g, D-13g	Sizes with pack (L-P-H mm)	635 - 555 - 675
Refrigerant	R404A	(L-P-H in)	25 - 21 14/16 - 26 9/16
Standard voltage	220-240 V ~ 50 Hz	Net weight	41 kg / 90 lbs
Electrical consumption	350 W	Gross weight	48 kg / 106 lbs
Fuse	10 A	Finish	AISI 304 stainless steel, scotch brite

All the technical information must be considered at the following conditions:

Sizes without feet  
 Standard Cube (18 g)  
 Ambient temperature +21° C  
 Water temperature +15° C  
 Electrical consumption at +43° C (standard voltage)

Models and specifications are subject to change without notice



BREMA ICE MAKERS SPA

Via dell'Industria 10,  
20020 Villa Cortese (MI), Italy

tel. +39 0331 434811  
fax +39 0331 433833

[www.bremaice.it](http://www.bremaice.it)  
info@bremaice.it

Bim + Data download



We are Brema

