



Undercounter ice maker up to 100 kg - Pebble system

Hotel	████████████████████
Restaurant	████████████████████
Fast food	████████████████████
Bar	████████████████████
Disco	████████████████████
Fish market	████████████████████
Supermarket	████████████████████
Medical & SPA	████████████████████
Industry	████████████████████

► Position n°



► Features & Plus

- Pebble ice - 91% dry
- 1l (water) - 1kg (ice) - only Air cooled
- AISI 304 SS Scotch Brite finish
- Tropical class +43°C
- Adjustable Stainless Steel feet
- Removable and cleanable air filter
- AISI 304 SS evaporator
- Air or water cooling system
- Easy cleanable internal rounded surfaces
- HCFC-Free insulated storage
- Dust-proof water basin
- RoHS Free
- Disappearing insulated door
- Electromechanical operation
- ON-OFF rocker switch
- Automatic water charge
- Standard voltages
- HFC free



AISI 304 SS Scotch Brite finish



Removable and cleanable air filter



AISI 304 SS evaporator



Dust-proof water basin



Disappearing insulated door

► Available pebble size

drawing for reference only

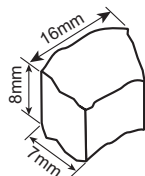

► Prod. 24h

Air temp.	Water temp.		kg	lb	
	10° C	50° F			7° C
21° C	70° F	15° C	60° F	90	198

► Certifications available for this model





Ice Pebbles

TB 852 HC



Undercounter ice maker up to 100 kg - Pebble system

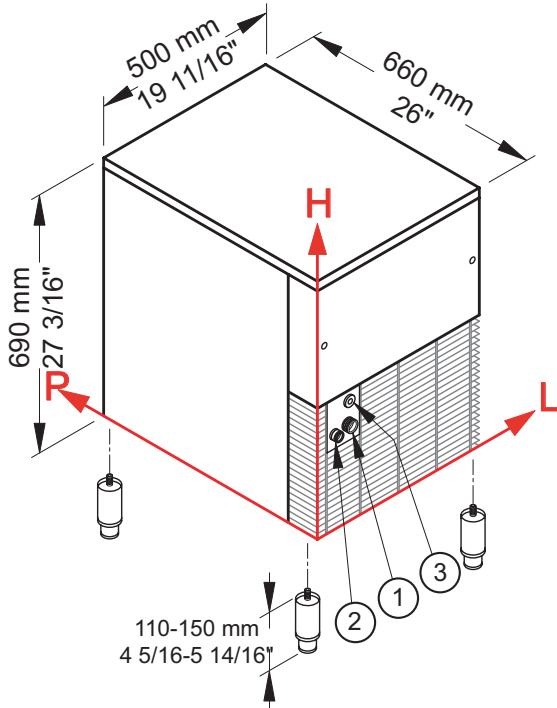

► Working conditions

- Location: **Indoor**

	Min	Max
Ambient temperature	+10° C / +50° F	+43° C / 110° F
Water temperature	+3° C / +37° F	+32° C / +90° F
Voltage	-10%	+10%
Water inlet pressure	1bar (14 psi)	6bar (84 psi)

► Performances

	Air temperature	Water temperature					
		7° C	45° F	15° C	60° F	21° C	70° F
	10° C	100 kg					
	50° F		220 lb				
	21° C			90 kg			
	70° F				198 lb		
	32° C					75 kg	
	90° F						165 lb

► Connections

All measures are referred to the rear bottom-left corner (L-H-Ø)

- ① Water in.: 99 mm / 3 14/16" - 158 mm / 6 4/16" - 3/4"
- ② Water out.: 48 mm / 1 14/16" - 151 mm / 5 15/16" - 24 mm / 15/16"
- ③ Electrical connections: 87 mm / 3 7/16" - 230 mm / 9 1/16"

► Technical information

Production in 24h	98 kg / 198 lb
Store capacity, up to	20 kg / 44 lb
Cooling system	A
Approximate pebble size	8 x 16 x 7
Refrigerant	R290
Standard voltage	220-240 V ~ 50 Hz
Average power consumption	410 W
Fuse	10 A
Electrical consumption	12 kWh/100kg

Water consumption	A: 1 l/kg - 12,0 gal/100 lb
Sizes (L-P-H mm)	500 - 660 - 690
(L-P-H in)	19 11/16 - 26 - 27 3/16
Sizes with pack (L-P-H mm)	550 - 720 - 880
(L-P-H in)	21 10/16 - 28 6/16 - 34 10/16
Net weight	59 kg / 130 lb
Gross weight	67 kg / 148 lb
Finish	AISI 304 stainless steel, scotch brite

All the technical information must be considered at the following conditions:

- Sizes without feet
- Ambient temperature +21° C
- Water temperature +15° C
- Electrical consumption at +32° C (standard voltage)
- Average power consumption at +43° C (standard voltage)

Models and specifications are subject to change without notice

Rev. 00 - Issued February 2017



BREMA ICE MAKERS SPA

Via dell'Industria 10,
20020 Villa Cortese (MI), Italy

tel. +39 0331 434811
fax +39 0331 433833

www.bremaice.it
info@bremaice.it

Bim + Data
download

