



Modular ice maker - Scale system Daily production up to 2450 kg

Hotel	████████████████████████████████████████
Restaurant	████████████████████████████████████████
Fast food	████████████████████████████████████████
Bar	████████████████████████████████████████
Disco	████████████████████████████████████████
Fish market	████████████████████████████████████████
Supermarket	████████████████████████████████████████
Medical & SPA	████████████████████████████████████████
Industry	████████████████████████████████████████

► Position n°



► Features & Plus

- Sub-cooled scale ice 99% dry
- 1l (water) - 1kg (ice) - only Air cooled
- AISI 304 SS Scotch Brite finish
- Tropical class +43°C
- Specific volume 1 m³ = 430 kg of ice
- Vertical fixed "no leak" evaporator
- AISI 316L SS evaporator
- Removable and cleanable air filter
- Cleanable antiscaling filter
- FDA approved - ABS plastic components
- Easy cleanable internal rounded surfaces
- RoHS Free
- Electromechanical operation
- Automatic water charge
- Standard and special voltages
- Frame in INOX



Vertical fixed "no leak" evaporator



Cleanable antiscaling filter



Frame in INOX

► Prod. 24h

⊖	Air temp.		Water temp.		Kg	Lbs
	7° C	45° F	10° C	50° F		
	21° C	70° F	15° C	60° F	2450	5401
					2300	5071

► Certifications available for this model





Ice Scales

Muster 2000



Modular ice maker - Scale system
Daily production up to 2450 kg

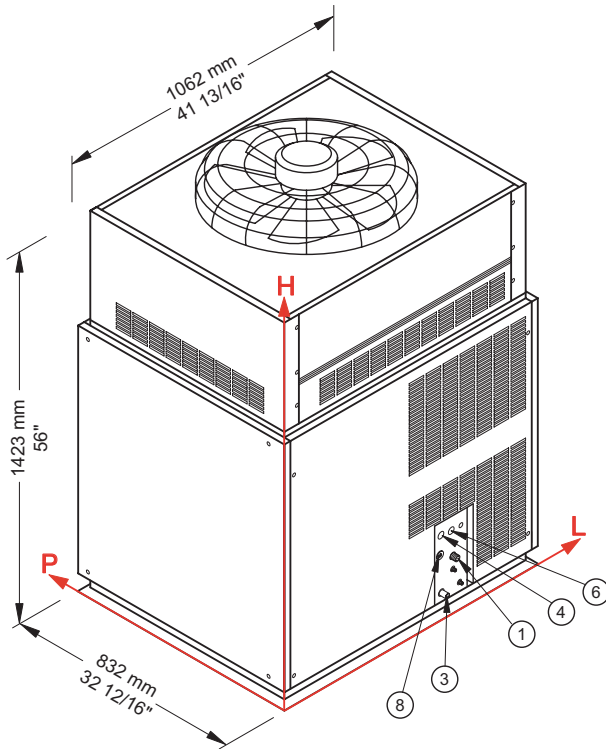

► Working conditions

- Location: **Indoor**

	Min	Max
Ambient temperature	+10° C / +50° F	+43° C / 110° F
Water temperature	+3° C / +37° F	+32° C / +90° F
Voltage	-10%	+10%
Water inlet pressure	1bar (14 psi)	6bar (84 psi)

► Performances

	Air temperature	Water temperature					
		7° C	45° F	15° C	60° F	21° C	70° F
	10° C	2450 kg					
	50° F		5401 lbs				
	21° C			2300 kg			
	70° F				5071 lbs		
	32° C					2034 kg	
	90° F						4484 lbs

► Connections

All measures are referred to the down-left corner (L-H-Ø)

- ① Water in.: 684 mm / 26 15/16" - 192 mm / 7 9/16" - 3/4"
- ② Water out.: 659 mm / 25 15/16" - 65 mm / 2 9/16" - 24 mm / 15/16"
- ③ Electrical connections: 651 mm / 25 10/16" - 271 mm / 10 11/16"
- ④ Remote connections.: 693 mm / 27 5/16" - 271 mm / 10 11/16"
- ⑤ Connection to feed pump: 640 mm / 25 3/16" - 232 mm / 9 2/16"

► Technical information

Production in 24h	2300 kg / 4071 lbs	Sizes (L-P-H mm)	1062 - 832 - 1423
Cooling system	A	(L-P-H in)	41 13/16 - 32 12/16 - 56
Refrigerant	R404A - R452A	Sizes with pack (L-P-H mm)	1150 - 960 - 1700
Standard voltage	400-415 V ~ 3N 50 Hz	(L-P-H in)	45 4/16 - 37 13/16 - 66 15/16
Electrical consumption	7000 W	Net weight	520 kg / 1146 lbs
Fuse	32 A	Gross weight	570 kg / 1257 lbs
Water consumption	A: 1 l/kg - 12,0 gal/100 lbs	Finish	AISI 304 stainless steel, scotch brite

All the technical information need to be considered at the following conditions:
Ambient temperature +21° C
Water temperature +15° C
Average power consumption at +21° C (standard voltage)
Refrigerant R404A

Models and specifications are subject to change without notice

Rev. 03 - Issued May 2018



www.bremaice.it
info@bremaice.it

Bim + Data
download

